

uLight (v.0.6.3)

The uLight is a controller designed to control lighting equipment, such as turn signals, brake lights, headlights, or LED strips. The uLight board has three CAN inputs and can function as a CAN splitter. Video [review](#) on YouTube. The uLight does not have its own power supply.

Technical specifications:

- Size 55x30x13 mm, weight 25 g
- Input 10-15V
- The current of one channel 3A, 6 outputs
- Total current ~ 10A (with external supply)
- 6 digital inputs
- 2 thermosensor inputs
- 2 digital outputs
- 3 CAN bus connectors

In the kit:

- uLight controller — 1 pcs.
- PHD 2.0 4P connector — 4 pcs.
- PHD 2.0 6P connector — 4 pcs.
- Power wires 22AWG 2x200 mm with connectors XH 2.54 2P — 6 pcs.
- Power wires 22AWG 300 mm with pins, crimped on both sides — 8 pcs.
- Wires 26AWG 300 mm with pins, crimped on both sides — 20 pcs.

Connection

You can look at the connection diagrams for other devices at this [link](#).

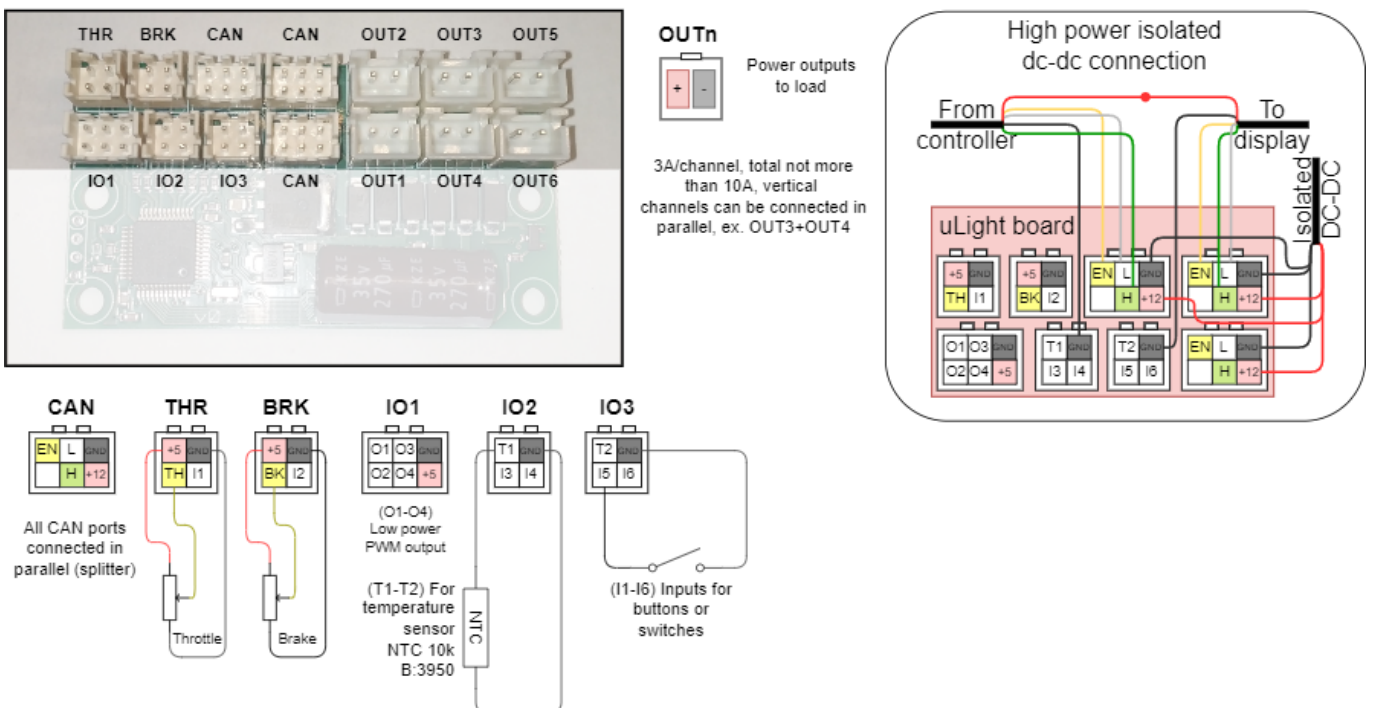

Connecting uLight to the Controller and the On-Board computer is possible in different ways: - By CAN-wire, which is purchased separately (not included in the kit). In this case, the standard CAN-wire from the Controller is connected to one of the CAN-ports on the uLight board, and the second CAN-wire from the uLight is connected to the On-board computer. - By standard CAN-wire between the On-board computer and the Controller. In this case, the CAN wire must be cut and crimped with two PHD 2.0 6P connectors (included in the kit). - By CAN wire through a CAN splitter, if it is used in your connection scheme, as a rule, such a scheme is used in all-wheel drive scooters with two controllers. In this case, it is better to connect the On-board computer directly to uLight, which is connected via a CAN wire to a CAN splitter, to which the Controllers are connected. If necessary, you can connect all peripherals to the uLight board to control the Controller (throttle levers, brakes, switch buttons) via the CAN bus without using the On-Board Computer. But, setting up the uLight and the Controller is possible only from the On-Board Computer. When all devices have been configured, the On-board computer can be disconnected. ===== The logic diagram =====

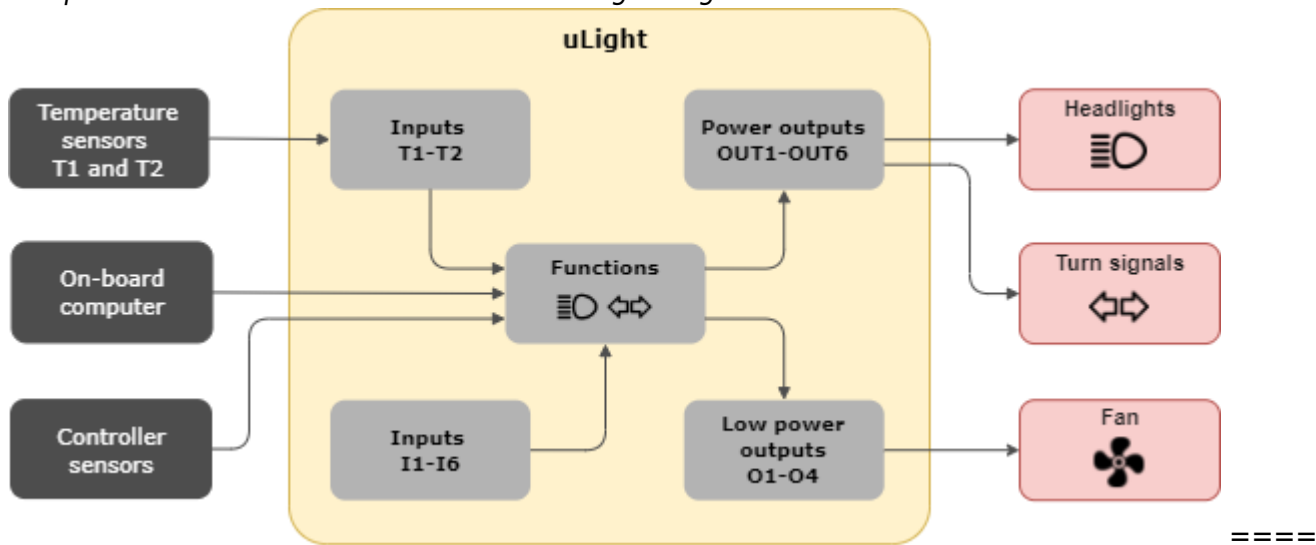

Setup ===== The uLight setup menu is located under **Settings > Devices > Nucular uLight**. Below you can find a detailed description of the menu items.

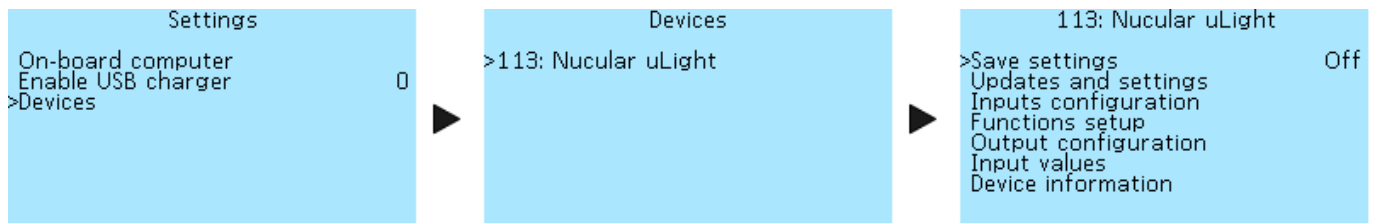

===== Save settings ===== Saving all settings made. Select **On** to save. If you do not save the settings, they will be reset after restarting of uLight. ===== Firmware updates ===== Section for working with firmware updates and settings. **Reboot** — some parameter settings, such as PWM and frequency, will be applied only after a reboot.

Load defaults — reset all settings made.
Update firmware — when you select **On**, the uLight firmware update will start, provided that an SD card with the firmware file is inserted into the On-board computer. You can download the current firmware version and read the update instructions in the **Firmware** section.

===== Inputs configuration ===== The functions of inputs **I1-I6** (see diagram above) are selected in

113: Inputs configuration			
T-sensor T1 type	Off		the Function setup section. Two thermal sensors can be connected to uLight.
# T-sensor T1	23.4°C		T-sensor T1 type — selection of NTC10K3950 or NTC10K3380
T1 Threshold (port I7.	50°C		thermal sensor. Select Off if no sensor is connected.
T1 Thr. mode	Normal		
T-sensor T2 type	Off		# T-sensor T1 — current temperature of the thermal sensor T1
# T-sensor T2	23.4°C		in degrees Celsius (°C).
T2 Threshold (port I8.	50°C		T1 Threshold (port I7) — I7 is a virtual port intended to
T2 Thr. mode	Normal		function setup (see Function setup). Values from 0°C to 250°C, in
CAN-Control	Off		1°C increments.
CAN-Ports	OFF		

T1 Threshold mode — signal operation mode from the thermal sensor, selection of values **Normal** (the signal state is first “off” when triggered is “on”) and **Inverted** (the signal state is first “on”, when triggered is “off”).

The settings for Temperature sensor T2 are similar to those for Temperature sensor T1.

CAN-Control — this setting refers to the **THR** (throttle), **BRK** (brakes), **IO2**, and **IO3** inputs on the uLight board and is used when the throttle, brakes and switches are connected directly to the uLight board. When you select the **On** setting, control signals from the inputs will be transmitted via the CAN bus and you will be able to control the Controller from the uLight board using the throttle, brake and switch inputs.

CAN ports — redirecting inputs to groups of CAN ports for controlling the controller. Selectable values — **OFF**, **CAN 1-8** and **CAN 9-16**. ===== Function setup ===== Function setup allows you to select which function each input on the uLight board or CAN input in the Controller or On-board computer corresponds to. All settings in this section of the menu have the same selection of functions:

Off — disabled.

On — enabled. If the lights are connected, they will light constantly.

I1-I6 — select the number of the input on the uLight board to which the switch for turning on the lights is connected. You can check the operation of the button in the menu section **Inputs values**, items **Input I1-Input I6**, when the button is turned on, the values will change to **On**.

I7_T1 and **I8_T2** — selection of the virtual port of the temperature sensor **T1** and **T2**.

C1-C16 — selection of the CAN input number when controlling via the CAN bus. It is used when [connecting](#) external control buttons to the On-board computer or when using the On-board computer buttons (Hot key). **C1-C16** are software values, there are fewer physical inputs on the boards,

```

113: Functions setup
>Shutdown by CAN          Off
# Turn signal setup #
Left turn switch          C9
Right turn switch         C10
Warning switch            C11
Turn brightness           100%
Turn on-time              0.4sec
Turn off-time             0.4sec
    
```

currently, eight CAN ports **IO1-IO8** are available on the On-board computer (see [diagram](#)).
Shutdown by CAN — this setting allows you to turn off all lighting equipment if you turned off the Controller but didn't turn off the power supply to the uLight board. The shutdown signal will be transmitted via the CAN bus and all lighting equipment will be turned off. The default is **Off** (Disabled). This setting is used if the uLight board has a separate power supply from an external direct current (DC) source. With the setting **On** (Enabled), the lighting equipment will continue to work when you turn off the power of the Controller and the On-Board Computer. If the uLight board receives power via the CAN bus and the **On** value is selected, uLight will turn off the power if it does not receive a CAN bus signal from any of the devices (Controller or On-board computer).

```

113: Functions setup
# Brake signal setup #
Off-brake brightness      20%
On-brake brightness       100%
# Reverse signal setup #
Off-reverse bright.       0%
On-reverse bright.        100%
# Beam setup #
>Low beam switch          C1
    
```

Turn signals setup
 Settings for the left and right turn signals. Read more about the setup below in the section **Turn signals setup**.
Left turn switch — setting for the left turn signal button.
Right turn switch — setting for the left turn signal button.

```

113: Functions setup
High beam switch          C2
Beam mode                 Separate
Beam min brightness       0%
Low beam brightness       100%
High beam brightness      100%
# Horn setup #
Horn switch               C11
># Fan control #
    
```

Warning switch — setting for the hazard warning light switch.
Turn brightness — select the brightness of the turn signals from 0% to 100% in 5% steps.
Time on-time — the speed of turning on the turn signals, together with setting the off time, allows you to control the speed of blinking of the turn signals. Values from 0.1 sec to 1 sec, in 0.1-sec increments.

```

113: Functions setup
High beam brightness      100%
# Horn setup #
Horn switch               C11
# Fan control #
Motor T-sensor
Controller T-sensor
T1 T-sensor
>T2 T-sensor
    
```

Turn off-time — turn off speed. Values from 0.0 sec to 1 sec, in 0.1-sec increments. Setting the value to 0.0 sec will disable the blinking function of the turn signals. **# Brake signal setup #**
 The brake signal is adjustable in two brightness levels.
Off-brake brightness — the brightness of the brake light when the brake is not pressed, for use as taillights, a value from 0% to 100% in 5% increments.

On-brake brightness — the brightness of the brake light when the brake is pressed, a value from 0% to 100% in 5% increments. **# Reverse signal setup #**

Adjust the brightness of the light of reverse. The uLight board does not have an input for the switch of reverse, therefore, this function is controlled from a switch connected to the On-board computer or Controller. When the Controller is turn on reverse, the signal on the uLight board will also be active.

Off-revers bright. — the brightness of the reversing light without engaging reverse, a value from 0% to 100% in 5% increments.

On-revers bright. — the brightness of the reversing light when reverse is engaged, a value from 0% to 100% in 5% increments. **# Beam setup #**

Low beam switch — the select setting for the low beam switch.

High beam switch — the select setting for the high beam switch.

Beam mode — this setting is selected depending on how the headlight is connected with one or two wires. **Single** — it is used if one headlamp performs the functions of low and high beam and is connected with one wire to one of the power outputs on the uLight board, for example, **OUT1**.

Separate — if two different headlights are used for low and high beam, or when one headlight is used, which has two lamps inside and is connected with two wires to two power outputs on the Microlight board, for example, **OUT1** and **OUT2**.

Beam min brightness — the brightness of the headlight when the power button is deactivated, for example for use as daytime running lights. Value from 0% to 100% in 5% increments. When using a

headlamp with a converter, the minimum brightness must be set to either 0% or 100%, the headlamp will flicker at intermediate values.

Low beam brightness — select the brightness of the low beam, values from 0% to 100% in 5% increments.

High beam brightness — select the brightness of the high beam, values from 0% to 100% in 5% increments. **# Horn setup #**

A horn can be connected to the uLight board, if necessary.

Horn switch — the select setting for horn switch. **# Fan control #**

Fan control allows you to adjust the cooling of the motor or Controller or using other scenarios using temperature sensors. Two temperature sensors can be connected to the uLight board. The setup menus for all temperature sensors are the same.

Motor T-sensor — motor temperature sensor.

Controller T-sensor — temperature sensor of the controller.

T1 T-sensor — external temperature sensor T1.

T2 T-sensor — external temperature sensor T2. The setup menus for all temperature sensors are the same. Below is a description of the menu using the example of a **T1 T-sensor**. **Temperature min** —

```

113: T1 T-sensor
>Temperature min      30°C
Temperature max      35°C
Output min            0%
Output max            100%

```

minimum temperature, values from -30 °C to 125 °C, in 5 °C increments.

Temperature max — maximum temperature, values from -30 °C to 125 °C, in 5 °C increments.

Output min — minimum output (PWM), values from 0% to 100%, in 5% increments.

Output max — maximum output (PWM), values from 0% to

100%, in 5% increments.

==== Output configuration ==== In this section, you can configure which output each function belongs to. The uLight has six power outputs **OUT1-OUT6** (see the diagram above). All outputs are PWM frequency adjustable.

```

113: Output configuration
>PWM 1-2 freq        100Hz
Output 1              LBeam
Output 2              HBeam
PWM 3-4 freq         100Hz
Output 3              Brk
Output 4              T1
PWM 5-6 freq         100Hz
Output 5              LBeam

```

PWM 1-2 freq — a setting for advanced users. Selectable PWM frequency values — **100Hz, 500Hz, 1kHz, 5kHz, 10kHz, 24kHz (FAN)**. For the usual light bulb, large values are not needed.

Select a frequency of 100Hz, this will be enough not to see flicker. The high-frequency marked FAN is used to control the fans, this is their standard frequency. **Output 1** — setting the function of

output 1 (**OUT1**) of the uLight board. Selectable values — **OFF** (Disabled), **ON** (Always on), **Bttn** (Button, not yet implemented), **TurnL** (Left turn signal), **TurnR** (Right turn signal), **Brk** (Brake),

LBeam (Low beam), **HBeam** (High beam), **Rev** (Reverse), **Horn**, **TMot** (Motor temperature), **TCont** (Controller temperature), **T1**

(External temperature sensor T1), **T2** (External temperature sensor T2). **Output 2** — the setting is similar to **Output 1**. The

frequency of **PWM 3-4** and **PWM 5-6** and their outputs **Output 3-6** are configured in the same way.

```

113: Output configuration
Output 5              LBeam
Output 6              HBeam
PWM IO mode           OFF
PWM IO freq           100Hz
Output P1             OFF
Output P2             OFF
Output P3             OFF
>Output P4           OFF

```

There is an **IO1** port on the uLight, in which there are four low-power PWM outputs **01-04**. They can connect, for example, an optocoupler. In the menu, you can select the mode of operation of the PWM at the outputs, its frequency, and the value of the function for each output. Outputs **01** and **02**, **03** and **04** can be connected in parallel to increase the total current. **PWM IO mode** — is a setting for advanced users. Selecting the PWM mode of the **IO** outputs — **OFF, Open-drain, Push-Pull**. **PWM**

IO freq — is a setting for advanced users. Selecting the frequency values of the PWM **IO** outputs — **100Hz, 500Hz, 1kHz, 5kHz, 10kHz, 24kHz (FAN)**. **Output P1** — setting the function of the PWM output of the low power **IO1** of the uLight. Selectable values — **OFF** (Disabled), **ON** (Enabled), **Bttn** (Button, not yet implemented), **TurnL** (Left turn signal), **TurnR** (Right turn signal), **Brk** (Brake), **LBeam** (Low beam), **HBeam** (High beam), **Rev** (Reverse), **Horn**, **TMot** (Motor temperature), **TCont** (Controller temperature), **T1** (External temperature sensor T1), **T2** (External temperature sensor T2). **Outputs P3-P4** are configured in the same way as **Output P1**. ===== Input values ===== In this section of the menu you can see the values of the indicators at each input of the uLight board. This menu is similar to the **Debug information** item in the Controller menu.

```

113: Input values
>Current          0.000 A
Voltage          12.094 V
Throttle         0.000 V
Brake            0.000 V
T-sensor internal 38.5°C
T-sensor T1      -37.5°C
T-sensor T2      23.4°C
Input I1         Off

```

Current — current consumption of headlights, Amperes (**A**).
Voltage — supply voltage of the uLight board, Volts (**V**).
Throttle — voltage on the throttle levers connected to the Microlight board, Volts (**V**).
Brake — voltage on the throttle levers connected to the uLight board, Volts (**V**).



```

113: Input values
T-sensor T1      -37.6°C
T-sensor T2      23.4°C
Input I1         Off
Input I2         Off
Input I3         Off
Input I4         Off
Input I5         Off
>Input I6         Off

```

T-sensor internal — the temperature at the uLight board temperature sensor, degrees Celsius (**°C**).
T-sensor T1 — temperature at the external temperature sensor T1 connected to the uLight board, degrees Celsius (**°C**).
T-sensor T2 — temperature at the external temperature sensor T1 connected to the uLight board, degrees Celsius (**°C**).
Input I1-Input I6 — values of buttons or switches connected to the uLight board, **Off** or **On**. When you turn on the button or switch connected to the uLight board, the values will change from **Off** to **On**, this functionality allows you to check the operation of

the buttons and to which board inputs they were connected.

===== Device information ===== Basic information about the uLight controller. In this menu, you can see what version of the firmware is loaded into your uLight controller.

```

113: Device information
>Nucular uLight
Firmware date    Jan 18 2021
Firmware ver.    0.4.1
Loader date      Jan 18 2021
Loader version    HW1.0 B1.3
Power cycle      0
Power-on time    0 min
                  0 h

```

Nucular uLight — is the name of the device.
Firmware date — date of compilation of the firmware.
Firmware ver — firmware version, you can check for updates in the [Firmware](#) section.
Loader date — date of compilation of the loader.
Loader version — the version of the data loader.
Power cycle — the number of uLight board power-ups.

Power-on time — the operating time of your uLight, minutes, hours, days.

===== Settings examples ===== Connecting and set up the headlight ===== In this example, we will look at the connection and setup of the headlight. To control the headlamp, we will use a three-wire, three-position switch. Turn signals and brake light are set up in the same way. Depending on the way the headlight is controlled, you can choose several settings: * control from external buttons of the switch connected to the uLight board. * control from external buttons of the switch connected to the On-board computer. * control from the buttons on the On-board computer.

==== Supply connection ==== Connect the headlamp according to the diagram (see above) to one of the **OUT1-OUT6** power outputs on the uLight board. Maximum current per channel 3A, total no more than 10A, which are available only when using an external DC converter. To connect, use the supplied uLight power wires 22AWG 2x200 mm with connectors XH 2.54 2P. Solder them to the headlight

wires, "+" and "-" respectively. If four wires are used to connect the headlight, then you can connect them to the power outputs of the uLight board in parallel vertically, **OUT1-OUT2, OUT3-OUT4, OUT5-OUT6**.

=== Control from external buttons of the switch connected to the uLight board === After connecting the headlight power supply, need to connect an external switch to the uLight board to control the headlight. For connection according to the diagram (see above) use inputs **I3-I4** of port **IO2** or **I5-I6**

```

113: Input values
T-sensor T1          -37.7°C
T-sensor T2          23.4°C
Input I1             Off
Input I2             Off
Input I3             Off
Input I4             Off
Input I5             On
>Input I6            Off

```

of port **IO3**. You can check the operation of the connected switch in the **Inputs values** menu section, when you turn the switch buttons on and off, the value of one of the inputs **I1-I6** to which you connected the switch will change from **Off** to **On**. You can also use this menu to see what input number the connected switch has before the output configuration setup. In the example on the screenshot the left, we see that one of the switch buttons

is connected to **Input I5**, the second button will change the value of **Input I6**. Next, you need to configure the outputs and their functions in the menu of the uLight board. The order of settings does not matter, the main thing is that the output corresponds to the function and vice versa.

== Function setup == You need to go to the **Function setup** menu and then, go to the **Beam setup**

```

113: Functions setup
# Beam setup #
Low beam switch     I3
>High beam switch  I4
Beam mode           Separate
Beam min brightness 0%
Low beam brightness 100%
High beam brightness 100%
# Horn setup #

```

section. Next, select which output the low beam switch is connected to, for example, you connected a switch button to **Output I3**. Next, select which output the high beam switch is connected to, for example, to **Output I4**. It is impossible to assign the inclusion of low and high beam to one button, only to a switch or to two separate buttons. For a description of the **Single** and **Separate** beam modes, see above in the **Beam setup** menu

section.

== Output setup == Go to the **Outputs configuration** menu, select the numbers of the **OUT1-OUT6** outputs to which the headlight is connected and assign them a function. For example, you connected a headlight with two pairs of wires to the **OUT1** and **OUT2** outputs. Taking into account

```

113: Output configuration
PWM 1-2 freq       100Hz
>Output 1          LBeam
Output 2           HBeam
PWM 3-4 freq       100Hz
Output 3           Brk
Output 4           T1
PWM 5-6 freq       100Hz
Output 5           LBeam

```

the previously made settings for the functions, go to **Output 1** and select the value **LBeam** (Low beam). Next, go to **Output 2** and select the **HBeam** (High beam) value. You can leave the PWM frequency for a regular bulb at **100Hz**. Then return to the main menu, go to the **Save settings** item and select **On** to save the settings. Done. Check the operation of the headlight in the low and high beam mode by turning on the switch buttons.

=== Control from external buttons of the switch connected to the On-board computer === After connecting the power supply for the headlight power supply, need to connect an external headlight control switch to the On-board computer. For connection according to the [diagram](#), use the inputs **IO1-IO3** of the **I/O1** port or **IO4-IO6** of the **I/O2** port located on the rear side of the On-board

```

Supply V 12.19 ACC Z -1280
Int +5V 5.20 Comp t 29
Light V 2.10 Input 1 func. 0
ThrottleV 0.00 Input 2 func. 1
Brake V 0.00 Input 3 func. 0
ACC X -281 Input 4 func. 0
ACC Y 947 Input 5 func. 0

```

computer. You can check the operation of the connected switch in the **On-board computer > Information** menu section, when you turn on and off the switch buttons, the value of one of the inputs **Input 1 func-Input 8 func** to which you connected the button will change from **0** to **1**. You can also use this menu to see what input number the connected switch button has before the stage of setting the outputs. In the screenshot on the left, the switch is connected to the On-board computer to the **I/O2** port and one of its buttons to the **IO2** input. Next, you need to configure the inputs in the On-board computer and their functions in uLight. The order of settings does not matter, the main thing is that the output corresponds to the function and vice versa.

== Setup inputs in the On-board computer == Need to go to the On-board computer menu and go to

```

Buttons setup
Input 1 type Switch
Input 1 func. CAN Button1
Input 2 type Switch
Input 2 func. CAN Button2
Input 3 type Switch
Input 3 func. CAN Button3
>Input 4 type Switch
Input 4 func. CAN Button4

```

the **Button setup menu** section. Next, need to select which input the **Low beam button** is connected to, for example, you connected the button to the **Input 2** input as in the example above. Go to the menu item **Input 2 func** and configure the function of the button, **CAN button 2**. Next, select the type of switch **Switch** in the menu item **Input 2 type**. Next, select which input the **High beam button** on the switch is connected to, for example, to **Input 3**. Go to the **Input 3 func** menu section. and configure the function of the **CAN button 3**. Next, select the type of button **Switch** in the menu item **Input 3 type**. After all the settings, go to the **Save settings** menu item and save the settings. This completes the setting of the switch connected to the On-board computer. Next, you need to configure the outputs and their functions in the menu of the uLight board. The order of settings does not matter, the main thing is that the output corresponds to the function and vice versa.

== Setup functions in the uLight == You need to go to the **Function setup** menu and go to the

```

113: Functions setup
# Beam setup #
Low beam switch C2
>High beam switch C3
Beam mode Separate
Beam min brightness 0%
Low beam brightness 100%
High beam brightness 100%
# Horn setup #

```

Beam setup menu section. Next, we select which input the **Low beam button** is connected to in the On-board computer, previously we connected the button to the **Input2** input and assigned the **CAN button2** function, which means we select the **C2** value. Next, select which input the **High beam button** is connected to, for example, to the **Input3** input and you assigned the **CAN button3** function, which means we select the **C3** value.

It is impossible to assign the inclusion of **Low and high beam** to one button, only to a switch or to two separate buttons.

== Output setup == Go to the **Output configuration** menu, select the numbers of the **OUT1-OUT6** outputs to which the headlight is connected and assign them a function. For example, you connected

```

113: Output configuration
PWM 1-2 freq 100Hz
>Output 1 LBeam
Output 2 HBeam
PWM 3-4 freq 100Hz
Output 3 Brk
Output 4 T1
PWM 5-6 freq 100Hz
Output 5 LBeam

```

a headlight with two pairs of wires to the **OUT1** and **OUT2** outputs. Taking into account the previously made settings for the functions, go to the **Output 1** section and select the **LBeam** (Low beam) value. Next, go to the **Output 2** section and select the **HBeam** (High beam) value. You can setup the PWM frequency for a regular bulb at **100Hz**. Then return to the main menu, go to the **Save settings** section and select **On** to save the settings. Done.

We check the operation of the low and high beam headlights by turning on the switch buttons.

=== Control from the buttons on the On-board computer === After connecting the headlight power supply, it is necessary to configure the On-board computer buttons. Go to the menu **On-board computer > Buttons setup**. All four front buttons of the On-board computer can be configured in the **Hot key1-Hot key4** menu sections. Buttons activate functions when pressed and held while the

```
Buttons setup
>Hot key 1 type      Button
Hot key 1 func.     CAN Button1
Hot key 2 type      Button
Hot key 2 func.     CAN Button2
Hot key 3 type      Button
Hot key 3 func.     Nothing
Hot key 4 type      Button
Hot key 4 func.     Nothing
```

Main screen is displayed. For example, you want to control the inclusion of the low beam with the first button on the screen. Go to the **Hot key 1 type** section, select the **Button**. Next, assign a function to the button in the **Hot key 1 func**, for example, **CAN Button1**. Similarly, we set up the second screen button to turn on the high beam on **CAN Button2**. After all the settings, go to the **Save** section menu and save the settings. This completes the

configuration of the On-board computer buttons. Next, you need to configure the outputs and their functions in the menu of the uLight board. The order of settings does not matter, the main thing is that the output corresponds to the function and vice versa.

== Setup functions in the uLight == You need to go to the **Functions setup** menu section and go to the **Beam setup** section. Next, select which button of the On-board computer the Low beam switch is connected to, we

```
113: Functions setup
# Beam setup #
Low beam switch      C1
High beam switch    C2
Beam mode            Separate
Beam min brightness 0%
Low beam brightness 100%
High beam brightness 100%
># Horn setup #
```

assigned the function **CAN Button1** to the first button, need to select the value **C1**. Next, we select which button of the On-board computer the High beam switch is connected to, we assigned the function **CAN Button2** to the second button, need to select the value **C2**. It is impossible to assign the inclusion of low and high

beam to one button, only to two separate buttons.

== Output setup == Go to the **Outputs configuration** menu section, select the numbers of the **OUT1-OUT6** outputs to which the headlight is connected and assign them a function. For example,

```
113: Output configuration
PWM 1-2 freq        100Hz
>Output 1           LBeam
Output 2            HBeam
PWM 3-4 freq        100Hz
Output 3            Brk
Output 4            T1
PWM 5-6 freq        100Hz
Output 5            LBeam
```

you connected a headlight with two pairs of wires to the **OUT1** and **OUT2** outputs. Taking into account the previously made settings for the functions, go to the **Output 1** section and select the **LBeam** (Low beam) value. Next, go to the **Output 2** section and select the **HBeam** (High beam) value. You can set up the PWM frequency for a regular bulb at **100Hz**. Then return to the main menu, go to the **Save settings** section and select **On** to

save the settings. Done. We check the operation of the low and high beam headlights by turning on the switch buttons.

==== Brake light setup ==== The setting is carried out in the same way as for connecting and setting up the headlight, except for the section **Control from external buttons of the switch connected to the uLight board**. Also read the description of the **Brake signal setup** menu section. ==== Reverse signal setup ==== Similar to connecting and setup the headlight. Also, read the description of the **Reverse signal setup** menu section. ==== Turn signal setup ==== Similar to connecting and setup the headlight. Also, read the description of the **Turn signal setup** menu section. ==== Horn setup ==== Similar to connecting and setup the headlight. Also, read the description of the **Horn setup** menu section. ==== Fan setup ==== Similar to connecting and setup the headlight. Also, read the description of the **Fan control** menu section. You can connect the fans directly to the controller through the **P1/P2** inputs of the **PWM** port (optional, need to order PWM wire). Detailed description in the section **Fan and Light Control**. ==== Temperature sensors setup ==== Read the description of the **Inputs configuration** menu section. When the temperature

sensors are connected to the uLight board, their temperature will not be displayed on the Main screen of the On-board computer, this functionality has not yet been released. ===== Throttle setup ===== Connect the throttle levers according to the [diagram](#) to the **THR** input on the uLight board. Next, go to the **Input values** menu section and check the operation of the throttle levers by switching it, the voltage value in the **Throttle** item should change. Next, go to the **Input configuration** menu section, then the **CAN control** section and select **On**. Next, you need to [set up](#) the voltage range of the throttle in the Controller. ===== Brake setup ===== Connect the brake levers according to the [diagram](#) to the **BRK** input on the uLight board. Next, go to the **Input values** menu section and check the operation of the brake levers by switching it, the voltage value in the **Throttle** item should change. Next, go to the **Input configuration** menu section, then the **CAN control** section and select **On**. Next, you need to [set up](#) the voltage range of the brake in the Controller.

From:

<https://docs.nucular.tech/> - **Nucular Electronics**

Permanent link:

<https://docs.nucular.tech/doku.php?id=en:ulight&rev=1662035396>

Last update: **2022/09/01 14:29**